

ROCKFORD

Drive Line

CV Centering Assemblies



End, Flanged, Weld & Repair Kits

MANUFACTURER OF DRIVELINE COMPONENTS
1500 11TH AVENUE ROCKFORD, ILLINOIS 61104
PHONE (815) 962-1411 FAX (815) 965-4857
RockfordDriveLine.com

How to Use This Section

Determine which type of stud yoke you need by referring to the illustrations and descriptions at the top of each page.

To identify a cv centering assembly (End Yoke Style)

1. Determine the series of the yoke. This can also be determined by measuring the bearing diameter **(A)** and snap ring lockup **(B)**.
2. Determine the Yoke Type within the series. At the top of the page we illustrate the (2) two different type of end yoke style yokes, **Type 1** (uses external seal) or **Type 2** (uses internal seal).
3. Determine the socket diameter **(F)** or reference the Repair Kit number used in the assembly. This may prove to be more helpful in confirming your application.

Bolt Pattern Dimensions & Threaded Hole Size are also included for additional identification.

Part series are shown in **Bold Italics** for easy lookup - RDL Kit number is also shown to the far right of each series for quick referencing.

RDL Part No.	Yoke Type	A Bearing Dia.	B U-Joint Lockup	Bolt Hole Dim.			F Socket Dia.	Repair Kit
				C	D	E		
1310 Series								Use RDL Kit - K153
R2-21-1355	Type 1	1.063	3.217	2.343	1.500	.312-24Thd	.500	404-0

To identify a cv centering assembly (Flanged Yoke Style)

1. Determine the series of the yoke. This can also be determined by measuring the bearing diameter **(A)** and snap ring lockup **(B)**.
*Note: Inside snap ring type yokes will show the B dimension followed by (I)
 Outside snap ring type yokes will show the B dimension followed by (O)*
2. Determine the Yoke Type within the series. At the top of the page we illustrate the (2) two different type of flanged yoke style yokes, **Type 1** (uses external seal) or **Type 2** (uses internal seal).

3. Determine the bolt pattern (**C & D**) and the bolt hole diameter (**E**)
4. Determine the socket diameter (**G**) or reference the Repair Kit number used in the assembly. This may prove to be more helpful in confirming your application.

Pilot Diameter & Centerline to Flange End are also included for additional identification.

Part series are shown in ***Bold Italics*** for easy lookup - RDL Kit number is also shown to the far right of each series for quick referencing.

RDL Part No.	Yoke Type	A Bearing Dia.	BO/BI U-Joint Lockup	Bolt Hole Dim.			F Pilot Dia.	G Socket Dia.	H CL to Flng End	Repair Kit
				C	D	E				

1350 Series

Use RDL Kit - K178

R2-21-2025	Type 2	1.188	3.622-O	3.000	3.000	M12x1.75	2.000-F	.500	1.625	404-0A
------------	--------	-------	---------	-------	-------	----------	---------	------	-------	--------

***To identify a cv centering assembly
(Weld Yoke Style)***

1. Determine the series of the yoke. This can also be determined by measuring the bearing diameter (**A**) and snap ring lockup (**B**).
2. Determine the hub diameter (**C**) or the socket diameter (**D**).
3. Determine the tube size (**E**) or the butt diameter (**F**).

Centerline to Weld & Repair Kit Number are also included for additional identification.

Part series are shown in ***Bold Italics*** for easy lookup - RDL Kit number is also shown to the far right of each series for quick referencing.

RDL Part No.	A Bearing Dia.	B U-Joint Lockup	C Hub Dia.	D Socket Dia.	E Fits Tube Size	F Butt Dia.	G CL to Weld	Repair Kit
--------------	----------------	------------------	------------	---------------	------------------	-------------	--------------	------------

2.5R Series

Use RDL Kit - K2532

R25-21-419	1.125	1.119	1.600	.470	65mm X 3mm	2.437	1.515	407-0
------------	-------	-------	-------	------	------------	-------	-------	-------

Notice: The data contained in this catalog has been thoroughly checked for accuracy, however we cannot assume any responsibility for errors, omissions or typographical mistakes that may appear.



CV CENTERING ASSEMBLY (End Yoke Style)

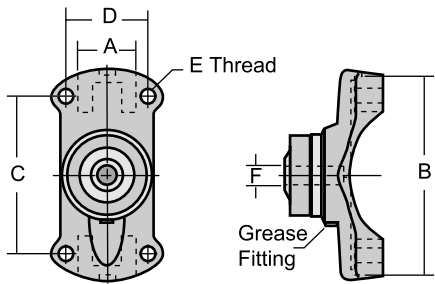

Type 1 (External Seal)

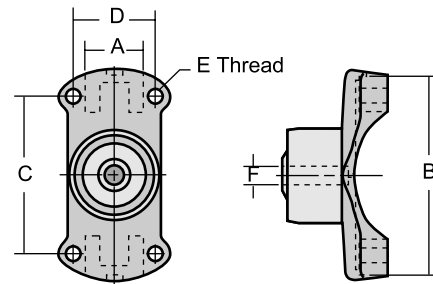

Type 2 (Internal Seal)

RDL Part No.	Yoke Type	A Bearing Dia.	B U-Joint Lockup	Bolt Hole Dim.			F Socket Dia.	Repair Kit
				C	D	E		
1210 Series				Use RDL Kit - K443				
R2-21-1342	Type 1	1.063	2.438	2.343	1.500	.250-28Thd	.500	404-0
1310 Series				Use RDL Kit - K153				
R2-21-1355	Type 1	1.063	3.217	2.343	1.500	.312-24Thd	.500	404-0
R2-21-1544	Type 2	1.063	3.217	2.343	1.500	.312-24Thd	.500	404-0A
1330 Series				Use RDL Kit - K1203 or K213				
R2-21-0841	Type 1	1.063	3.622	2.875	1.500	.312-24Thd	.625	405-0
R2-21-1179	Type 1	1.063	3.622	2.875	1.500	.312-24Thd	.500	404-0
R2-21-1996	Type 2	1.063	3.622	2.875	1.500	.312-24Thd	.500	404-0A
1350 Series				Use RDL Kit - K178				
R3-21-2019	Type 2	1.188	3.622	2.750	1.625	.312-24Thd	.500	404-0A

CV CENTERING ASSEMBLY (Flanged Yoke Style)

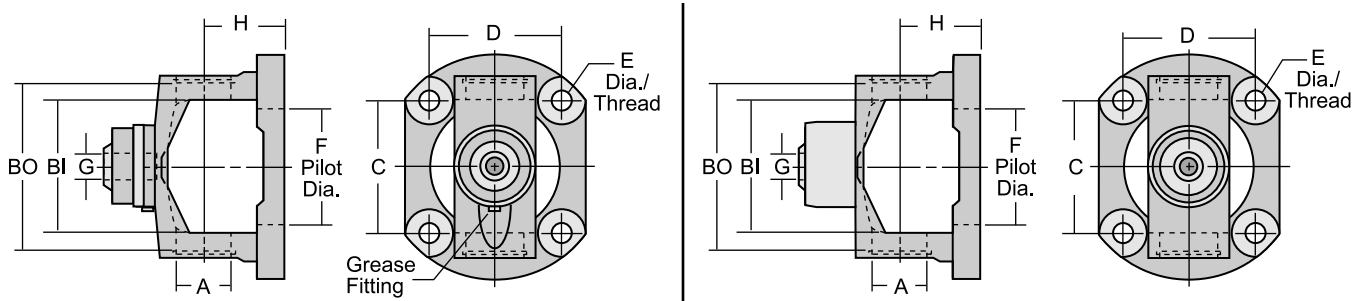

Type 1 (External Seal)

Type 2 (Internal Seal)

RDL Part No.	Yoke Type	A Bearing Dia.	BO/BI U-Joint Lockup	Bolt Hole Dim.			F Pilot Dia.	G Socket Dia.	H CL to Flng End	Repair Kit
				C	D	E				

1210 Series

Use RDL Kit - K443

R2-21-1489	Type 1	1.063	2.437-O	2.478	2.478	.484	2.000-F	.500	1.625	404-0
------------	--------	-------	---------	-------	-------	------	---------	------	-------	-------

1310 Series

Use RDL Kit - K153

R2-21-1229	Type 1	1.063	3.217-O	2.478	2.478	.484	2.000-F	.500	1.625	404-0
R2-21-1229LH**	Type 1	1.063	3.217-O	none	none	none	2.000-F	.500	1.625	404-0
R2-21-1543	Type 2	1.063	3.217-O	2.478	2.478	.484	2.000-F	.500	1.625	404-0A

1310 Series (Saginaw Conversions)

Use RDL Kit - K153

R2-21-3124	Type 1	1.063	3.217-O	2.938	2.662	.453	3.125-F	.500	1.625	404-0
										*Early Style Bolt Pattern
R2-21-1452	Type 1	1.063	3.217-O	3.000	3.000	.453	3.125-F	.500	1.625	404-0
										*R3R-21-482 Bolt Pattern

1310 Series (Suzuki Conversions)

Use RDL Kit - K153

R2-21-3162	Type 1	1.063	3.217-O	2.210	2.210	.328	1.770-M	.500	1.625	404-0
										*Samuri With 3.120 Bolt Circle

1310 Series (Toyota Conversions)

Use RDL Kit - K153

R2-21-3116	Type 1	1.063	3.217-O	2.360	2.360	.410	1.809-M	.500	1.625	404-0
										*R25-2-3143 Bolt Pattern
R2-21-3123	Type 1	1.063	3.217-O	2.596	2.596	.445	1.809-M	.500	1.625	404-0
										*R25-2-3144 Bolt Pattern
R2-21-3114	Type 1	1.063	3.217-O	2.696	2.364	.328	1.809-M	.500	1.625	404-0
										*R25-2-3138 Bolt Pattern

** New addition to MC0906-1 catalog



CV CENTERING ASSEMBLY (Flanged Yoke Style)

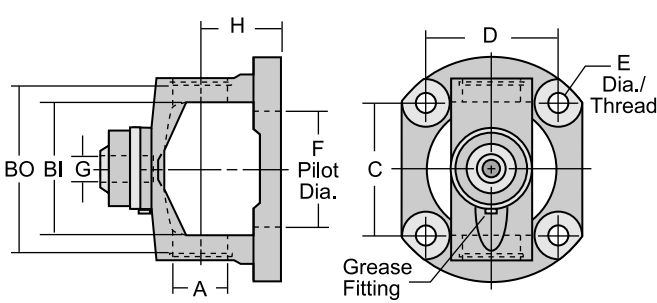

Type 1 (External Seal)

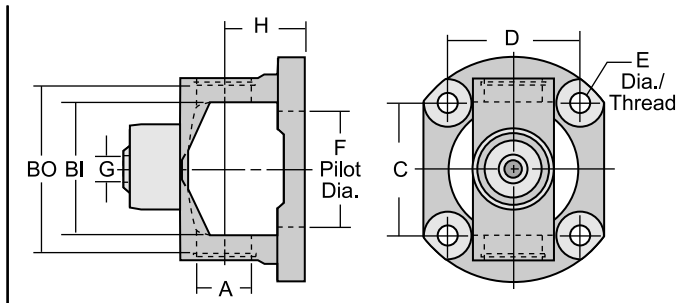

Type 2 (Internal Seal)

RDL Part No.	Yoke Type	A Bearing Dia.	BO/BI U-Joint Lockup	Bolt Hole Dim.			F Pilot Dia.	G Socket Dia.	H CL to Flng End	Repair Kit
				C	D	E				

1310 Series (Toyota Conversions) cont.

Use RDL Kit - K153

R2-21-3174	Type 1	1.063	3.217-O	2.696	2.364	.394	1.809-M	.500	1.625	404-0
										*R25-2-3142 Bolt Pattern
R2-21-3115	Type 1	1.063	3.217-O	2.750	2.426	.394	1.809-M	.500	1.625	404-0
										*R25-2-3140 Bolt Pattern

1330 Series

Use RDL Kit - K1203 or K213

R2-21-1606	Type 1	1.063	3.622-O	2.953	2.656	.453	3.125-F	.500	1.625	404-0
R2-21-1520	Type 1	1.063	3.622-O	2.953	2.656	.453	3.125-F	.625	1.625	405-0
R2-21-1631	Type 2	1.063	3.622-O	3.000	3.000	M12x1.75	2.000-F	.500	1.625	404-0A
R2-21-1868	Type 2	1.063	3.622-O	3.000	3.000	.453	3.125-F	.500	1.625	404-0A

3R Series

Use RDL Kit - K3147

R3R-21-3124**	Type 2	1.125	2.560-I	2.643	2.933	.453	3.125-F	1.111	1.705	403-0
R3R-21-627**	Type 2	1.125	2.560-I	3.000	3.000	.413	3.125-F	1.111	1.705	403-0
R3R-21-482	Type 2	1.125	2.560-I	3.000	3.000	.453	3.125-F	1.111	1.705	403-0

1350 Series

Use RDL Kit - K178

R3-21-2024	Type 2	1.188	3.622-O	3.000	3.000	M12x1.75	2.000-F	.500	1.625	404-0A
R3-21-2025	Type 2	1.188	3.622-O	3.000	3.000	M12x1.75	2.688-F	.500	1.625	404-0A
R3-21-3281**	Type 2	1.188	3.622-O	3.000	3.000	.453	3.125-F	.500	1.625	404-0A

1350 Series (Conversion)

Use RDL Kit - K178

R3-21-3136	Type 2	1.188	3.622-O	2.478	2.478	.484	2.000-F	.500	1.625	404-0A
										*R2-21-1229 Bolt Pattern
R3-21-3184	Type 2	1.188	3.622-O	3.000	3.000	.453	3.125-F	.500	1.625	404-0A
										*R3R-21-482 Bolt Pattern

CV CENTERING ASSEMBLY (Flanged Yoke Style)

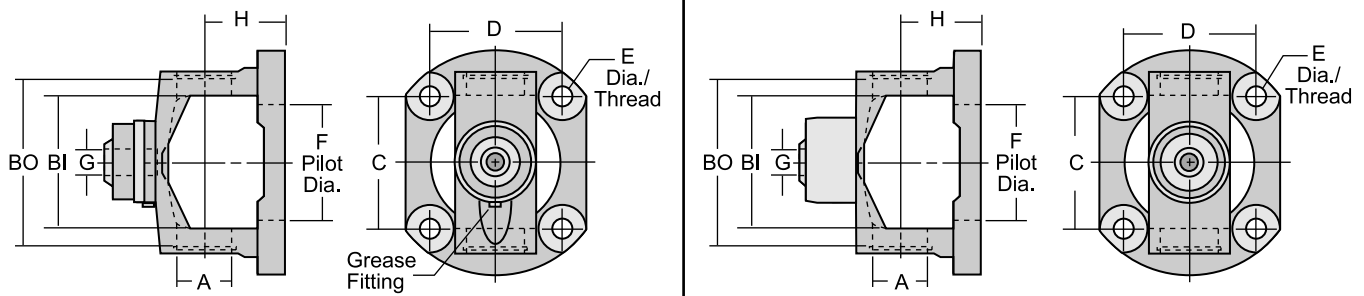

Type 1 (External Seal)

Type 2 (Internal Seal)

RDL Part No.	Yoke Type	A Bearing Dia.	BO/BI U-Joint Lockup	C	Bolt Hole Dim. D	E	F Pilot Dia.	G Socket Dia.	H CL to Flng End	Repair Kit
--------------	-----------	----------------	----------------------	---	------------------	---	--------------	---------------	------------------	------------

1355 Series (Saginaw Style Ball Kit)

Use RDL Kit - K178

R3-21-7324	Type 2	1.188	3.622-O	3.000	3.000	M12x1.75	2.000-F	1.111	1.625	403-0
------------	--------	-------	---------	-------	-------	----------	---------	-------	-------	-------

CV CENTERING ASSEMBLY (Weld Yoke Style)

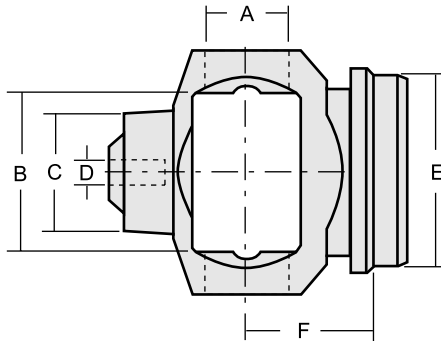

RDL Part No.	A Bearing Dia.	B U-Joint Lockup	C Hub Dia.	D Socket Dia.	Fits Tube Size	E Butt Dia.	F CL to Weld	Repair Kit
--------------	----------------	------------------	------------	---------------	----------------	-------------	--------------	------------

2.5R Series (Toyota)

Use RDL Kit - K2532

R25-21-522	1.125	2.125	1.575	.844	—	1.625-F	1.850	512-0
R25-21-3145	1.125	2.125	1.600	.470	2.00 x .120	1.770	1.515	407-0
R25-21-3146	1.125	2.125	1.600	.470	2.50 x .083	2.344	1.515	407-0
R25-21-419	1.125	2.125	1.600	.470	65mm X 3mm	2.437	1.515	407-0
R25-21-3147	1.125	2.125	1.830	.511	2.00 x .120	1.770	1.515	409-0
R25-21-3148	1.125	2.125	1.830	.511	2.50 x .083	2.344	1.515	409-0
R25-21-420	1.125	2.125	1.830	.511	65mm X 3mm	2.437	1.515	409-0



CV HOUSING YOKES (Borg-Warner Style)

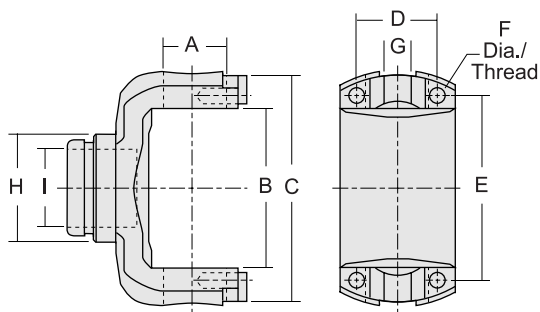

Type 1 (Round Bearings)

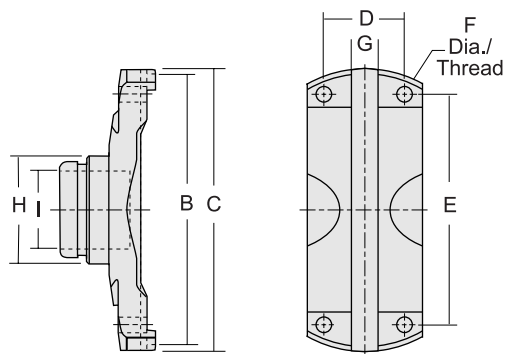

Type 2 (Block Bearings)

RDL Part No.	Yoke Type	A Bearing Dia.	B U-Joint Lockup	C Swing Dia.	Bolt Hole Dim.			G Key Width	H Socket Dia. (OD)	I Socket Dia. (ID)	Repair Kit
					D	E	F				
5R Series		Use RDL Kit - 505-10									
R5R-21-525	Type 1	1.312	3.313	4.780	1.687	3.871	.375-24Thd	.558	2.252	1.625	516-0
6C Series		Use RDL Kit - 506-10									
R6C-21-526	Type 2	—	5.530	5.840	1.687	4.494	.375-24Thd	.560	2.252	1.625	516-0*
7R Series		Use RDL Kit - 507-10									
R7R-21-527	Type 1	1.625	4.375	6.563	2.188	5.146	.500-20Thd	1.000	2.502	1.875	517-0

*Note: On 6C applications used for constant speed applications the 518-0 should be used

CV REPAIR KITS

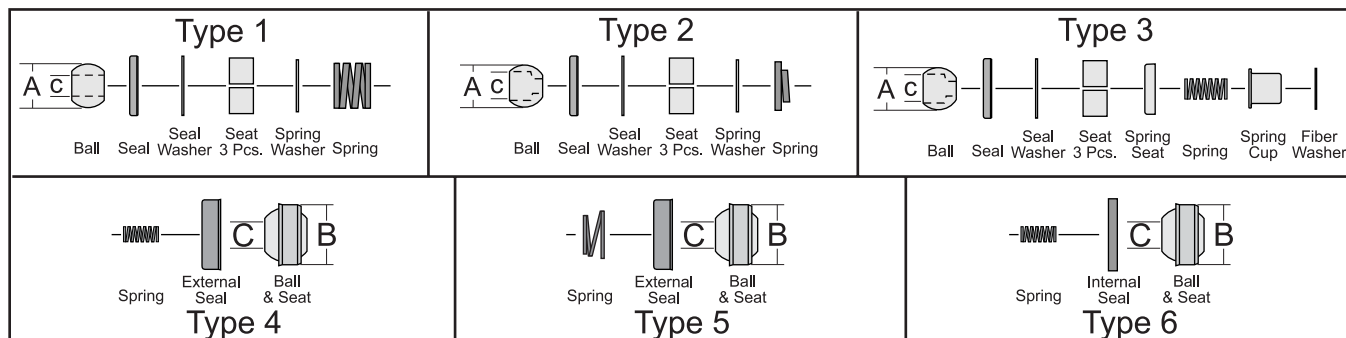

RDL Part No.	Kit Type	A Ball Diameter	B Gimble Diameter	C Socket Diameter	Reference Notes
403-0	Type 1	.906	—	.457	Saginaw - (W/ Ball)
403-0A	Type 1	—	—	—	Saginaw - (W/O Ball)
403-01	Type 2	.875	—	.598	Saginaw - (W/ Ball)
403-01A	Type 2	—	—	—	Saginaw - (W/O Ball)
403-02	Type 3	.875	—	.598	Saginaw - (W/ Ball)
403-02A	Type 3	—	—	—	Saginaw - (W/O Ball)
403-02S	Type 1	.906	—	.457	Saginaw - (W/ Ball & Short Spring)
403-03	Type 1	.906	—	.625	Saginaw - (W/ Ball)
404-0	Type 4	—	1.252	.500	Spicer - (Early)
405-0	Type 5	—	1.252	.625	Spicer - (Early)
404-0A	Type 6	—	1.252	.500	Spicer - (Late)
407-0	Type 6	—	1.340	.470	Toyota - (1st Design)
409-0	Type 6	—	1.456	.511	Toyota - (2nd Design)

CV REPAIR KITS (Borg-Warner)

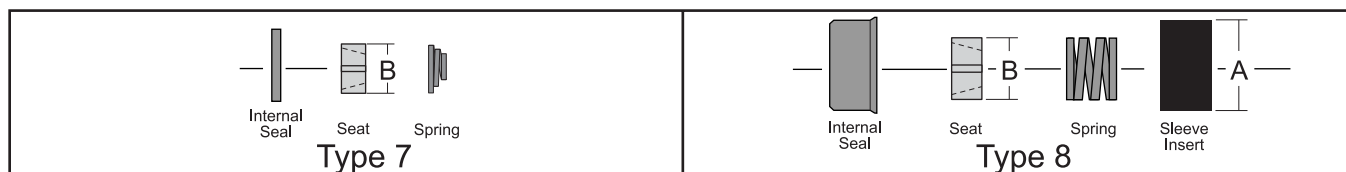

RDL Part No.	Kit Type	A Sleeve Outside Dia.	B Sleeve Inside Dia.	C Gimble Diameter	Reference Notes
512-0	Type 7	—	—	1.027	2.5R Series
516-0	Type 8	2.500	2.249	1.621	5R/6C Series (200 Lb. Spring)
518-0	Type 8	2.500	2.249	1.621	6C Series (80 Lb. Spring)
517-0	Type 8	2.725	2.499	1.870	7R Series

Note: On 6C applications the lighter spring is used for constant speed applications.



PART NUMBER INTERCHANGE LIST

MFG. NO.	OUR NO.	MFG. NO.	OUR NO.
Neapco		408A	R2-21-1489
2-9201	403-0A	409	R3-21-2019
2-9203	403-01A	419	R25-21-419
2-9205	403-02A	420	R25-21-420
2-9302	403-0	483	R2-21-3124
2-9303	403-01	483T	R2-21-3114
2-9305	403-02	484	R2-21-1452
7-0081	404-0	490A	R3R-21-482
7-0081 NG	404-0A	522	R25-21-522
7-0041	R2-21-0841	525	R5R-21-525
7-0042	R2-21-1342	526	R6C-21-526
7-0079	R2-21-1179	527	R7R-21-527
7-0079NG	R2-21-1996		
7-0082	R2-21-1355	Spicer	
7-0082NG	R2-21-1544	210476-1X	405-0
N2-83-388X	R2-21-1229	211407X	407-0
N2-83-288X	R2-21-1489	210841X	R2-21-0841
N2-83-288-1X	R2-21-3114	211007X	403-0A
N2-83-489X	R2-21-1489	211009X	403-0
N2-83-543X	R2-21-1543	211010X	403-01A
N2-83-631X	R2-21-1631	211011X	403-01
N2-83-913X	R2-21-1868	211012X	403-02A
N3-83-019X	R3-21-2019	211013X	403-02
N3-83-024X	R3-21-2024	211179X	R2-21-1179
N3-83-025X	R3-21-2025	211229X	R2-21-1229
N3-83-3281X	R3-21-3184	211342X	R2-21-1342
N3-83-3281X	R3-21-3281	211355X	R2-21-1355
N3R-83-482	R3R-21-482	211452X	R2-21-1452
N3R-83-627	R3R-21-627	211489X	R2-21-1489
		211520X	R2-21-1520
		211543X	R2-21-1543
		211544X	R2-21-1544
		211606X	R2-21-1606
		211631X	R2-21-1631
		211868X	R2-21-1868
		211996X	R2-21-1996
		212019X	R3-21-2019
		212024X	R3-21-2024
		212025X	R3-21-2025
Rockford (Old Numbers)			
404	R2-21-1355		
404A	R2-21-1229		
404B	R2-21-1544		
405	R2-21-0841		
406	R2-21-1179		
406AC	R2-21-1868		
406AF	R2-21-1631		
406B	R2-21-1996		
406TJ	R2-21-1606		
408	R2-21-1342		

PART NUMBER INDEX



PART NUMBER	PG	PART NUMBER	PG
403-0	9	R25-21-3146	7
403-0A	9	R25-21-3147	7
403-01	9	R25-21-3148	7
403-01A	9	R3-21-2019	4
403-02	9	R3-21-2024	6
403-02A	9	R3-21-2025	6
403-02S	9	R3-21-3136	6
403-03	9	R3-21-3184	6
404-0	9	R3-21-3281**	6
404-0A	9	R3-21-7324	7
405-0	9	R3R-21-482	6
407-0	9	R3R-21-627**	6
409-0	9	R3R-21-3124**	6
512-0	9	R5R-21-525	8
516-0	9	R6C-21-526	8
517-0	9	R7R-21-527	8
518-0	9		
R2-21-0841	4		
R2-21-1179	4		
R2-21-1229	5		
R2-21-1229LH	5		
R2-21-1342	4		
R2-21-1355	4		
R2-21-1452	5		
R2-21-1489	5		
R2-21-1520	6		
R2-21-1543	5		
R2-21-1544	4		
R2-21-1606	6		
R2-21-1631	6		
R2-21-1868	6		
R2-21-1996	4		
R2-21-3114	5		
R2-21-3115	6		
R2-21-3116	5		
R2-21-3123	5		
R2-21-3124	5		
R2-21-3162	5		
R2-21-3174	6		
R25-21-419	7		
R25-21-420	7		
R25-21-522	7		
R25-21-3145	7		

** New addition to MC0906-1 catalog

MANUFACTURER OF DRIVELINE COMPONENTS
1500 11TH AVENUE ROCKFORD, ILLINOIS 61104
PHONE (815) 962-1411 FAX (815) 965-4857
RockfordDriveLine.com